

Reliable underground communications using pilot or power cores

Powerful Broadband Powerline Modem (BPLM) range promotes assisted automation and improved mining operations in complex environments underground



SPITFIRE®

Creates a reliable network connection across multiple machines in order to transmit data between equipment and the surface



**SUPER
SPITFIRE®**

Extends the communications network to work over longer distances

NETWORK TECHNOLOGY

Network challenges in underground mining include confined spaces, lack of GPS, explosive atmosphere, weak strata and complex mining machinery. As such, use of powerline for communications is best for underground, tethered vehicles.

Network	Open Cut	Underground Hard Rock	Underground Soft Rock
Wide Areas	●		
Confined Spaces		●	●
No GPS		●	●
Chemical Attack		●	●
Explosive Atmosphere			●
Weak Strata			●
Complex Mining Machinery			●

Technology	Ethernet	Fibre	Radio	Powerline
Data Rate		Best		
Distance	Worst	Best		
Environmental Survival		Worst		Best
Drop-Outs			Worst	
Infrastructure Burden				Best
Mobile			Best	

Harnessing Technology to Keep Miners Safe

NAUTITECH® is an Original Technology Manufacturer (OTM) and global provider of smart electronic and software solutions for OEMs and mine sites in underground mining.

We design and manufacture equipment that delivers **Communications and Visibility**, supports **Automation**, and provides a platform for **Asset and Condition Monitoring** of underground equipment. Our **DataMaster data analytics** software can help detect safety risks and gain intelligence for improved mining operations.



SOFT ROCK MINING

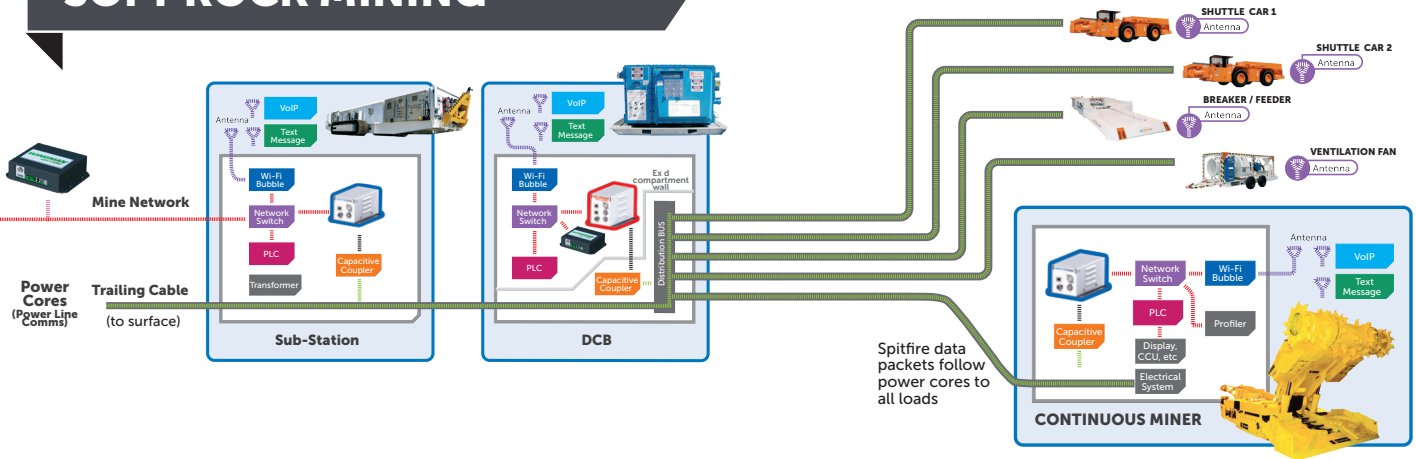

HARD ROCK MINING

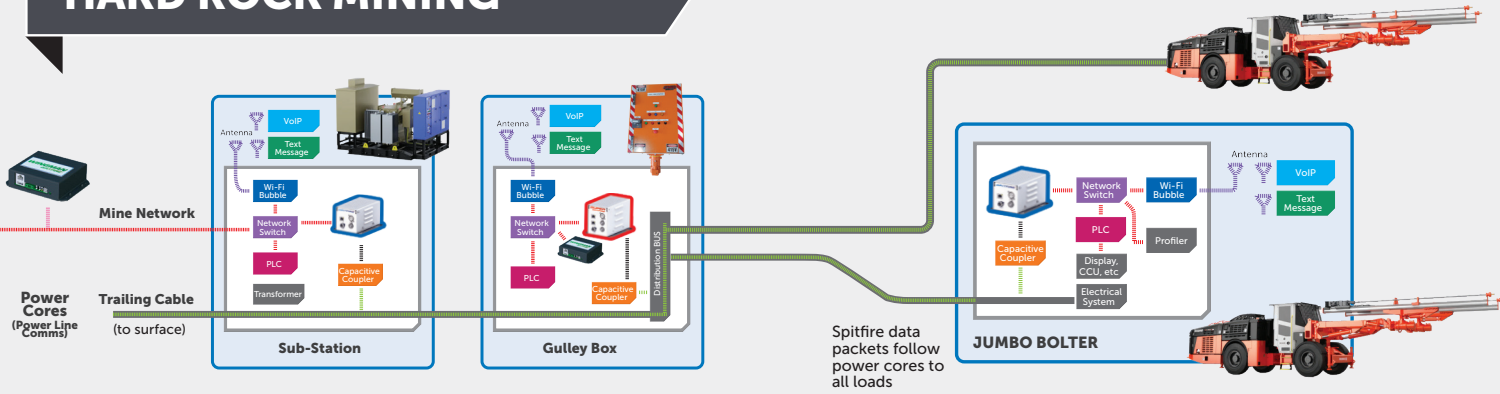

Environmental Specifications

Supply voltage	85 to 264 VAC
Supply frequency	50 Hz, 60 Hz
Supply power, max	12 W
Ethernet interface	10BASE - T/100BASE-TX Shielded RJ45
Operating temperature	0° to 60°C
Vibration	IEC 60068-2-6
Shock	IEC 60068-2-27
EMC emissions	IEC 61000-6-4
EMC immunity	IEC 61000-4-2/3/4/5/6/8

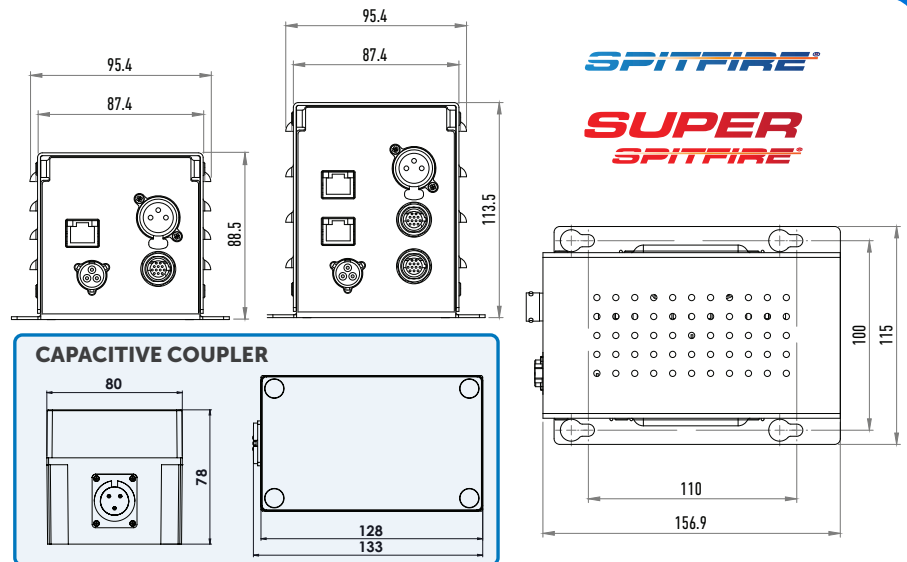

Scan QR Code to watch the Spitfire in action

Nautitech's Spitfire Broadband Power-line modem range

Australian Patent: 2016 356 720
 United States Patent: 10,735,049
 European Union Patent: 3378165
 South African Patent: 2018/02984

